

Flat Packer FP9

Colour	T mm	W mm	L mm
Clear	1	9	80
Clear	2	9	80
Clear	3	9	80
Clear	4	9	80
Clear	5	9	80
Clear	6	9	100

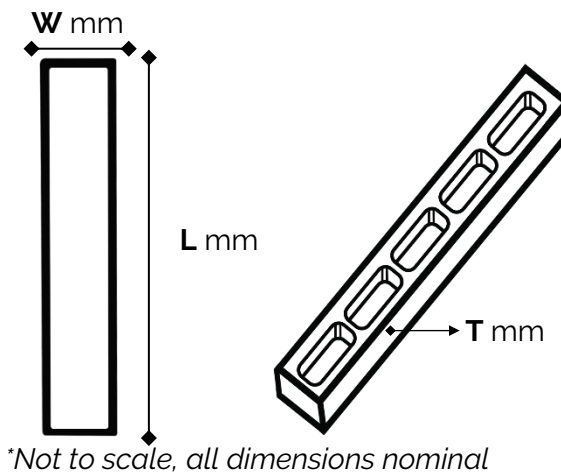

Processing:

The below data has been taken from our raw material data sheet.

Injection Moulding

Control Property:	ISO Method	Units	Values
Melt Flow Rate (230°C/2.16 kg)	1133	g/10 min	12

Typical Properties ^a :	ISO Method	Units	Values
Density	1183-1	g/cm ³	0,903
Flexural Modulus - 1% secant	178	MPa	1050
Tensile Strength at Yield	527-1	MPa	24
Tensile Elongation at Yield	527-1	%	6
Shore Hardness (D Scale)	868	-	70
Notched Izod Impact Strength at 23°C	180	kJ/m ²	40
Notched Izod Impact Strength at -20°C	180	kJ/m ²	6
Deflection Temperature under Load at 0.455 MPa	75-1/75-2	°C	88
Vicat Softening Temperature at 10N	306	°C	145

a) Injection molded specification according to ISO 294.